

# Bristolite's Industrial Skylights

## Fiberglass Steel Louvered Smoke Hatch Dome Model SSHDL

The Fiberglass Steel Framed Smoke Hatch Ventilator Domes, manufactured with cost saving galvanized steel, are skylights with maximum ventilating capacity consistent with moisture resistant design and low profile appearance providing natural lighting and ventilation as well as emergency automatic heat and smoke venting.

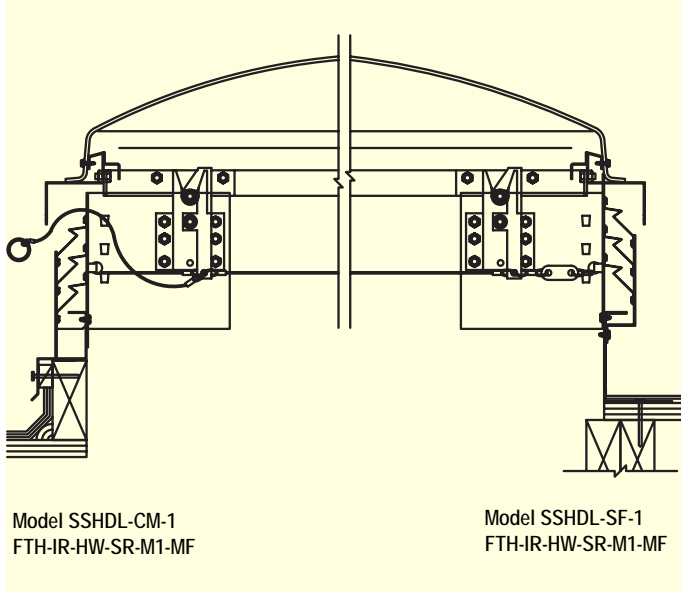

Typical Self-Flashing and Curb Mount Details

**Specifications:** Louvered Smoke Hatch Domes shall be No. H\_\_\_\_\_ as manufactured by Bristolite Skylights, Santa Ana, Calif. The fiberglass dome shall be a molded one piece unit with integral counterflashing skirt to eliminate any dependence on gaskets, sealants or flow-through designs. The Fiberglass dome shall consist of neopentyl glycol isothalic gelcoat laminate with an acrylic modified polyester based resin and silene glass fiber. The dome is attached to an operable frame. The operable frame is attached to the base frame with a hinge. The operable frame is compression loaded by torsion spring and secured on the opposite side by a latch system operated with a UL Listed and FM approved fusible link. The operable frame comes attached to a louvered frame. The louvers will be fixed storm resistant louver blades of galvanized steel and shall be continuous. The louvered frame is attached to a base frame of galvanized steel and shall be installed either on a 1-1/2" wide curb furnished by others or on its own 4" high self-flashing curb fabricated from galvanized steel with a 2-3/4" roof flange. Materials are to be self-extinguishing Approved Plastic Rated CC-1. All materials are to be guaranteed against defective workmanship and materials.

### Standard Features Include:

1. **High Wind Resistance** - Can withstand high wind conditions.
2. **Curb-Mounted** (specify by adding **CM** to model description) or **Self-Flashing** (specify by adding **SF** to model description)
3. **Exterior Manual Outside Release** (specify by adding **M1** to model description) or **Interior Manual Release** (specify by adding **M2** to model description)
4. **Fusible link temperatures:** 165°, 212°, 286°, or 360°

### Options

1. **Exterior-Interior Manual Release** (specify by adding **M3** to model description)
2. **Dust Filters** (specify by adding **DF** to model description)
3. **Insect Screens** (specify by adding **IS** to model description)
4. **Bird Screens** (specify by adding **BS** to model description)
5. **Rain Guard** (specify by adding **RG** to model description)
6. **Security Grills** (for specific information see our product information for Security Grills.)

### Model Description

SSHDL	Galvanized Steel Smoke Hatch Louvered
CM	Curb Mount Frame
SF	Self-Flashing Frame
1	Single Non- Insulated Dome
FTH	Fiberglass Translucent (High)
IR	Impact Resistant
HW	High Wind Resistant
SR	Storm Resistant Louver Blade
M1	Exterior Manual Outside Release
MF	Mill Finish

### Available Sizes

Model Number	Inside Curb Opening	Amount of Free Air Space
H4896 -SSHDL	48" x 96"	9 square feet